

## VIS-4

### Voice Intercom Switch with Dial Down Feature

CPE/Premise Wiring

MDU

Utility/Municipality



VIS-4

VIS-4 Voice Intercom Switch is a microprocessor controlled circuit that provides seamless connection of customer premise telephones to either a digital voice service or to door answering systems (DAS)/intercom calls in multiple dwelling units (MDUs).

When the customer telephone line is not in use, a ringing signal on the DAS/intercom line is detected and connected to the premise telephones. Connection to the DAS/intercom is established when the customer telephone is taken off hook. A dropped DAS/intercom call or placing the telephone back on hook terminates the DAS/intercom call, and the VIS-4 automatically restores the digital voice service connection to the premise telephone wiring.

If the customer telephone is in use when the DAS/intercom rings, a double beep (similar to a call waiting tone) is injected on to the digital voice line to alert the user of an incoming DAS/intercom call. The user is then able to tap the flash key on the phone handset to place the original call on hold and pick up the DAS/intercom call. Another tap/flash after completion of the DAS/intercom call will initiate the switch back to the original call that was on hold.

The default state of the VIS-4 connects the customer telephone to the digital voice service, with a blinking green LED indicating that the device's voice side is powered. In the event of power loss on the digital line, the VIS-4 connects the premise telephone wiring to the DAS/intercom system so that it may still be used during the power outage. Upon restoration of the digital voice line power, the premise telephones are connected back to the digital voice service.

The VIS-4 includes touch tone decoder circuitry to enable the user to dial the concierge/front desk by dialing #. For example, the dial down feature for the Trigon System will be activated by entering "#48#", hang up and wait for the concierge call back.

#### KEY PRODUCT BENEFITS

- ▶ Can be located next to the existing DAS/intercom connection.
- ▶ Customer is able to attend to DAS/intercom calls while using digital voice service on existing phones.
- ▶ Eliminates the need for separate telephone sets to answer DAS/intercom calls.
- ▶ DAS/Intercom system remains fully functional in the event of power loss on voice line
- ▶ Provides dial down feature to access concierge/front desk of the MDU by dialing special access code
- ▶ For indoor applications only

#### INDUSTRY STANDARDS

- ▶ Listed to UL 1863



**Tii Technologies Inc.**

**Corporate Headquarters:**

141 Rodeo Drive  
Edgewood, NY 11717

Phone: 631.789.5000

Fax: 631.789.5063

Toll Free: 888.844.4720

sales@tiitech.com

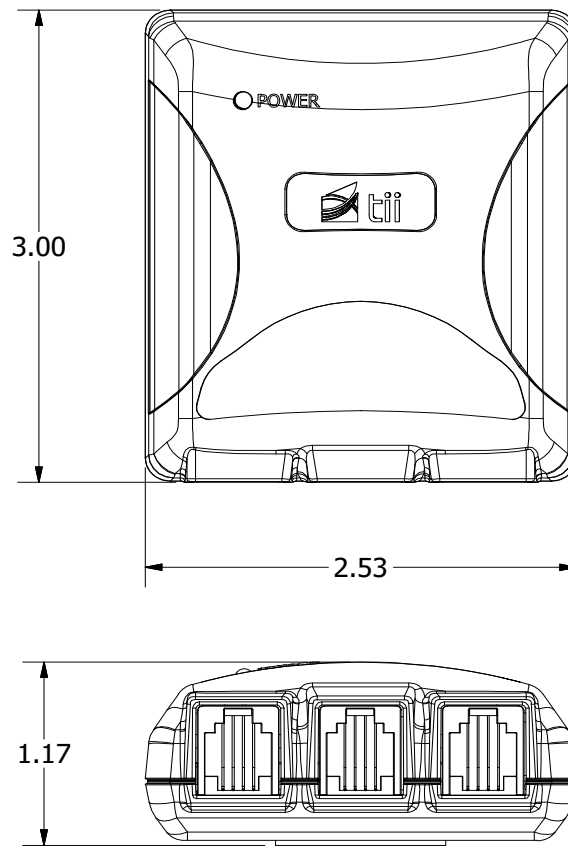

Dimensions are in Inches

<b>Operating Voltage Range</b>	40-60 Volts DC
<b>Ring Voltage</b>	60-90 Volts AC
<b>Operating Current - From Digital Voice Phone Line</b>	
ON Hook State (25-50 V)	< 1 mA
OFF Hook State (first 5 seconds)	< 3 mA
OFF Hook State (3-20 V, post 5 seconds)	< 1.25 mA
<b>Operating Current - From DAS/Intercom Phone Line</b>	
Device in DAS/Intercom State	< 10 $\mu$ A
<b>Intercom Ring Signal Delay</b>	< 50 ms
<b>Operating Temperature</b>	-40 to 60°C

## ORDERING INFORMATION

Model No.	Description	Standard Pkg.
<b>VIS-4</b>	Voice Intercom Switch with Dial Down Feature and Intercom Default on Power Loss	20 pieces, 0.1875 lbs. per unit