

173- 73- Series

1-Pin and 5-Pin Gas Tube Protector Modules

CPE/Premise Wiring

Headend/CO

Utility/Municipality

Wireless



173-3C3EW-NL

Tii gas tube modules are dependable plug-in devices that guard sensitive telecommunications systems from dangerous voltage surges. The gas tube utilizes a three-element design. This prevents destructive line-to-line over voltages, protecting PBXs and key systems in a way that conventional two-element gas tubes cannot.

The modules include heat activated fail-safe mechanism that provides additional protection against power crosses. Test points allow easy test access to the outside plant.

KEY PRODUCT BENEFITS

- ▶ Designed for line protection for sensitive voice and data equipment
- ▶ Balanced three-electrode design
- ▶ Extends equipment life
- ▶ Protects personnel

INDUSTRY STANDARDS

- ▶ Listed to UL 497 for Primary Protection
- ▶ Telcordia GR-974



Tii Technologies Inc.

Corporate Headquarters:

141 Rodeo Drive
Edgewood, NY 11717
Phone: 631.789.5000
Fax: 631.789.5063
Toll Free: 888.844.4720
sales@tiitech.com

173, 73 Gas Tube Protector Series

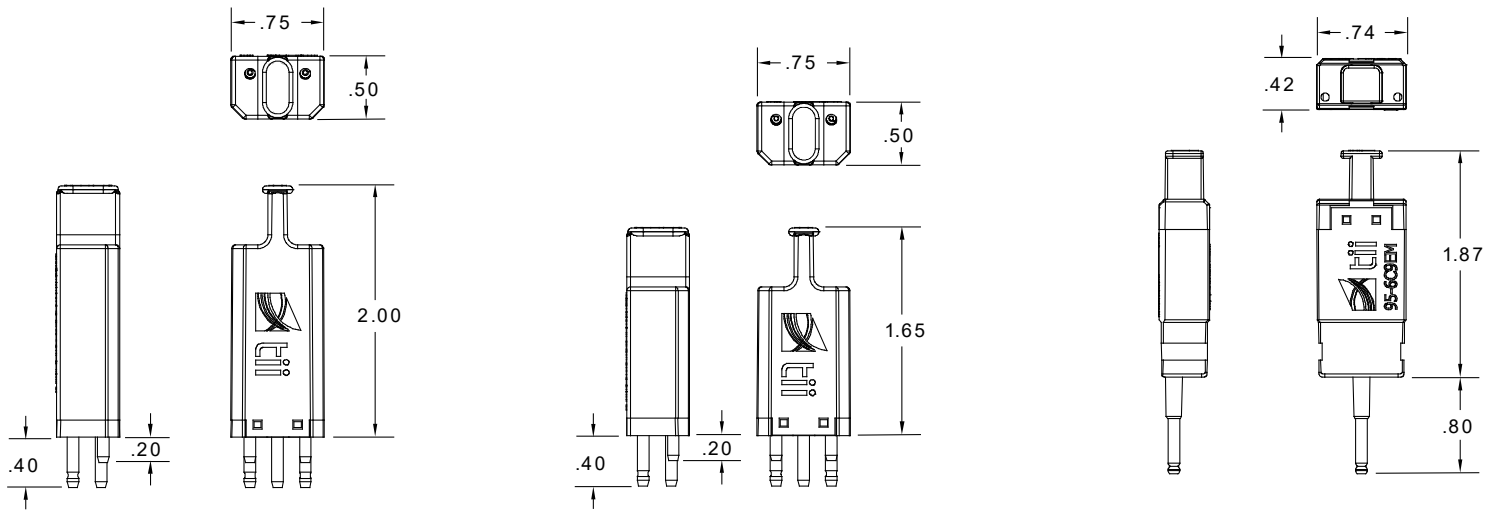

Dimensions are in Inches

SPECIFICATIONS

	350 Volt	Test Parameters
DC Breakdown Voltage	280-420V	2000V/Sec max
Impulse Breakdown Voltage	<1000V	100V/ μ Sec max
Capacitance	10 pF	1 MHz, 0 VDC
Fail-safe Operation	100 Sec @ 0.5A 50 Sec @ 1.0A 15 Sec @ 5.0A 10 Sec @ 20.0A	
Line Series Resistance	NA	Line in/ Line Out
Maximum Single Surge	24kA	8/20 μ Sec max
Insulation Resistance (minimum)	100M Ω	50 VDC 100VDC
DC Holdover:		
52V	260mA	<150 mSec max
135V	200mA	to extinguish
150V	140mA	
Operating Temperature	-40° C to +65° C	

ORDERING INFORMATION

Model No.	Description
73-3C3EW-N	350V, Single Pin Protector Module with Red Body with Test Points
173-3C3EW-N	350V, 5-Pin Protector Module with 1.65" Red Body with Test Points
173-3C3EW-NL	350V, 5-Pin Protector Module with 2" Red Body with Test Points
173-3B3EW-N	350V, 5-Pin Protector Module with 1.65" Red Body without Test Points
173-3B3EW-NL	350V, 5-Pin Protector Module with 2" Red Body without Test Points

* Remove (-N) for Gold Pins.

INFORMATION CONTAINED IN THIS PUBLICATION IS PROVIDED ONLY FOR YOUR CONVENIENCE AND IS SUBJECT TO CHANGE WITHOUT NOTICE. TII TECHNOLOGIES MAKES NO REPRESENTATIONS OR WARRANTIES OF ANY KIND WHETHER EXPRESS OR IMPLIED, WRITTEN OR ORAL, STATUTORY OR OTHERWISE, RELATED TO THE INFORMATION, INCLUDING BUT NOT LIMITED TO ITS CONDITION, QUALITY, PERFORMANCE, MERCHANTABILITY OR FITNESS FOR PURPOSE; AND TII TECHNOLOGIES DISCLAIMS ALL LIABILITY ARISING FROM THE USE OF THIS INFORMATION.